UNIT - II

Air Ticket



- Passenger should hold a valid ticket
 - Upon arrival should be given to get a Boarding pass
 - Types of ticket
 - Paper ticket
 - E- Ticket
- **Manual ticket**
- **Automated ticket**

Types of Air Ticket

- Electronic ticketing is a method to document the sale and track the usage of passenger transportation without the issuance of paper documents.
- A record of all activity is kept in an electronic ticket file.
- Since the information is electronic and stored electronically in the validating carrier's database they cannot be stolen and therefore there is no need for replacement of lost tickets.

Reading and Interpreting Air tickets

- An electronic ticket is used in the same way as a paper ticket.
 - All the information called “Data elements” relating to a passenger’s itinerary, fare, class, payment taxes etc is stored in an electronic record in the database of the validating carrier.
-

Boarding Pass

- A **boarding pass** or **boarding** card is a document provided by an airline during check-in, giving a passenger permission to enter the restricted area of an airport (also known as the airside portion of the airport) and to **board** the airplane for a particular flight.
-

-
- A boarding pass includes the legal name of the passenger and flight information including:
 - Airline name
 - Departure gate information
 - Departure and arrival cities
 - Flight numbers
 - Departure time
 - Boarding time
 - Boarding group number
-

-
- There will also be a bar code (paper boarding pass) or QR code (mobile boarding pass) for scanning at the security checkpoint and when you board the plane.
-

Frequent-Flyer Program

- A **frequent-flyer program (FFP)** is a loyalty program offered by an airline.
 - Many airlines have frequent-flyer programs designed to encourage airline customers enrolled in the program to accumulate points (also called miles, kilometers, or segments) which may then be redeemed for air travel or other rewards.
-

Frequent Flyer Cards

- Points earned under FFPs may be based on the class of fare, distance flown on that airline or its partners, or the amount paid.
- There are other ways to earn points.
- For example, in recent years, more points have been earned by using co-branded credit and debit cards than by air travel.
- Another way to earn points is spending money at associated retail outlets, car hire companies, hotels, or other associated businesses.
- Points can be redeemed for air travel, other goods or services, or for increased benefits, such as travel class upgrades, airport lounge access, fast track access, or priority bookings.

Excess Baggage Charge (Weight & Piece Concept)

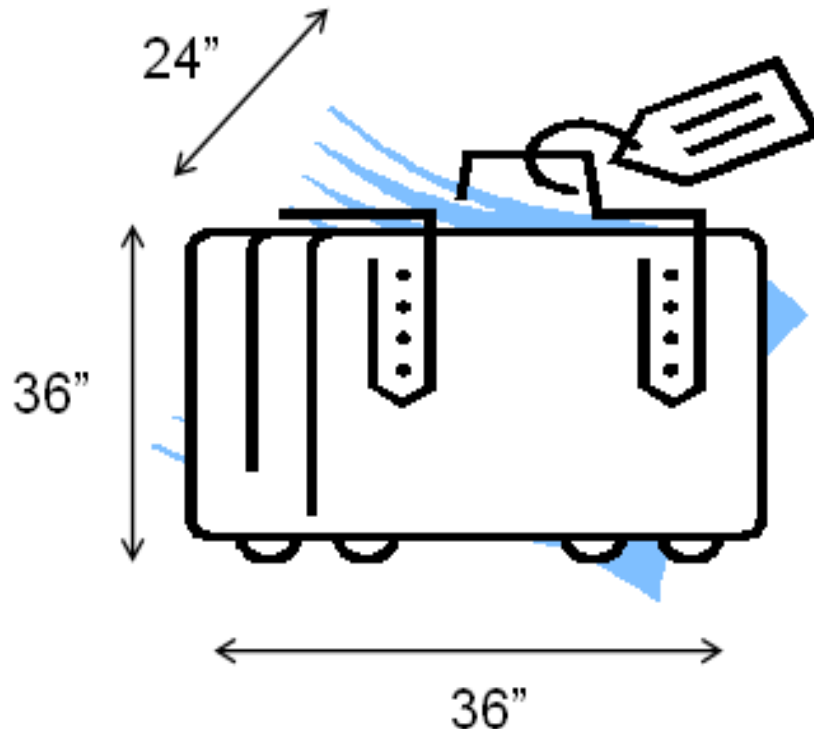

Baggage



- Equivalent to luggage; articles, effects and other personal property of a passenger as are necessary or appropriate for wear, use, comfort or convenience in connection with his trip
 - Two types- Checked Baggage & Unchecked baggage
 - Baggage allowance- amount of baggage each passenger is allowed to transport free of charge
 - Any piece over the baggage allowance or baggage that exceeds the size and weight limitations will be subject to additional charges. Excess baggage is transported on a space-available basis and will be carried subject to load capacities of the aircraft.
-

How a Bag is Measured???

- A bag will be weighed and measured to ensure that it meets the dimensional requirements for shipping.
 - Baggage is measured by length + width + height. The dimensions of each measurement are added together to compose the total number of linear inches/ centimeters
 - The bag's thickest or widest part of the length, width and height will be measured.
 - The maximum allowed baggage dimensions are:
Length : 30" , Width :12" & Height : 20" (Check In Baggage)
Length : 20" , Width : 10" & Height : 14" (Cabin Baggage)
-

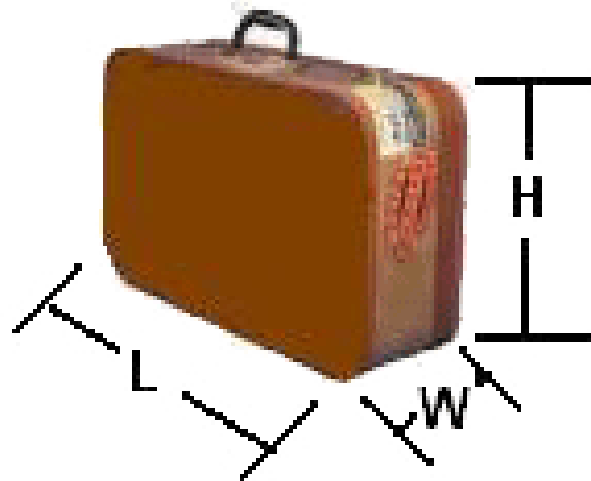

**L=Length, W= Width &
H=Height**

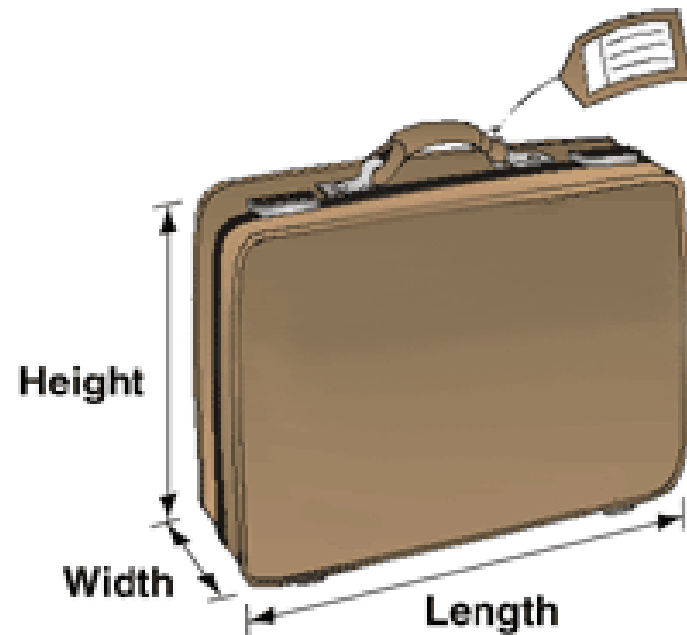

Boeing

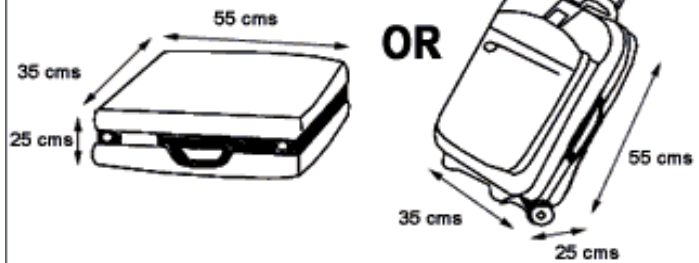

Airbus

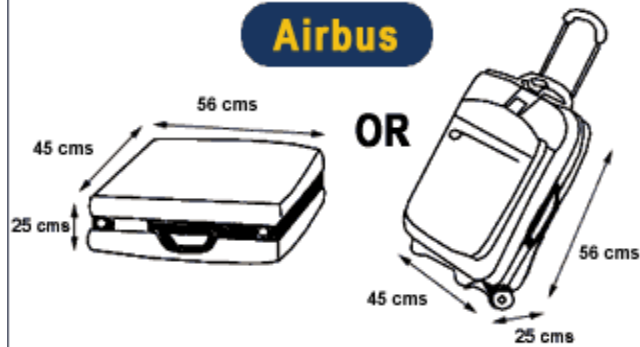

ATR

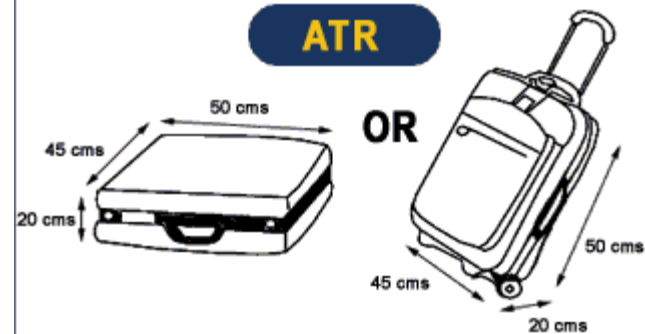

The Free Baggage Allowance

Weight Concept:

- For Travel starting from India to Europe/Far East/Middle East a passenger is allowed Free Baggage allowance by the airlines that is based on the class of travel.
- A child gets the equivalent allowance as an adult. Infant are not allowed any free baggage allowance, except for items like Strollers or Infant's utility bag.
- Normally, the following entitlement is allowed based on the class of travel :-

- ✧ First Class: 40 Kg
- ✧ Business Class: 30 Kg
- ✧ Economy Class: 20 Kg



Piece Concept:

Countries where the piece system applies

- Between USA/US Territories and all countries.
 - Between Canada and Europe, Middle East, Southern Africa, South Asian Subcontinent, the Far East except Guam and South West Pacific, Argentina, Bolivia, Brazil, Chile, Mexico, Panama, Paraguay, Peru, Uruguay.
 - Between the Far East and Argentina, Bolivia, Brazil, Chile, Panama, Paraguay, Peru, Uruguay, Mexico, USA.
 - Between Guam/Saipan and Japan, Okinawa, Hong Kong, Korea Republic, China, Taiwan, Philippines, Thailand, Indonesia, Malaysia, Singapore, India. between Pago Pago and South West Pacific.
-

Standards according to IATA

Checked Baggage - (Weight Concept)		
Class	Adults & Children (age 2+)	Infants
First	40 kg *	10 kg
Business	30 kg *	10 kg
Economy	20 kg *	10 kg

Continued...

Checked Baggage - (Piece Concept)	
Class	To/from Canada & USA
First	<ul style="list-style-type: none">☞ 2 pieces, the sum of the three dimensions (l+w+h) of each piece must not exceed 158 cm (62 in.) and is limited to 23 kg.☞ Infant- 1 piece
Business	<ul style="list-style-type: none">☞ 2 pieces- 158 cm (62 in.) is limited to 23 kg.☞ Infant- 1 piece
Economy	<ul style="list-style-type: none">☞ 2 pieces- 158 cm (62 in.) is limited to 23 kg.☞ Infant- 1 piece

Cabin Baggage Allowance

- In order to ensure safety of aircraft and passengers as well as the convenience of fellow passengers, only 1 piece of cabin baggage of specified dimensions can be carried in the cabin.
- The sum of the three dimensions not exceeding 115 cm/45in and below 10kgs.

The following items are permitted :

- ☺ An overcoat, wrap or blanket, an umbrella or a walking stick
 - ☺ A lady's handbag, lady's pocketbook or lady's purse
 - ☺ A reasonable amount of reading matter for the flight
 - ☺ A small camera and/or a pair of binoculars
 - ☺ Infant's food for consumption in flight and infant's carrying basket
 - ☺ A fully collapsible invalid's wheelchair and/or a pair of crutches and/or braces or other prosthetic device for the passenger's use provided that the passenger is dependent upon them.
-

Excess Baggage Charge

- A passenger's baggage presented at check-in that is in excess of free allowance- excess in weight; excess in total diameter; excess piece; fragile things and the like.
- A charge is payable for excess baggage (Normally 1% of Basic fare for 1 kg)
- This may vary depending upon the terms and conditions of carriage, flying country, and the like.



Valuable or Fragile Items as Checked Baggage

You are advised against packing of such items in your checked in baggage. The list of these items may include the following:

- Laptops
- Money
- Jewelry / Precious Metals
- Silverware
- Business / Travel or Identification Documents
- Medicines or drugs
- Negotiable Papers
- Securities
- Other valuables

